



A-1802-0928

Coolgap bobbin
Planar ER51/10/38

DIMENSIONS - Height 15,45mm x Diameter 41,40mm
PLANAR ER CORES

Featured/applications

Coolgap is an innovative cooling system that removes the heat directly from the source. In inductive components, higher power density and lower losses can be achieved thanks to the considerable reduction of the temperature at its origin, resulting in a global weight and volume reduction of the part.

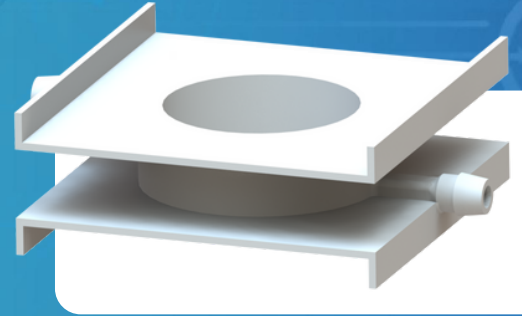

01 MATERIAL PROPERTIES

Coilformer material	High-temperature resin
Thermal conductivity	0,63 W/mK
Specific heat	951 J/kgK
Density	1721 kg/m ³
Thermal expansion coefficient	47 $\mu\text{m}/\text{m}^\circ\text{C}$
Thermal class (IEC61857-21)	155°C (F)
Compatibility	Good water, glycol and oil compatibility

02 MECHANICAL DIMENSIONS

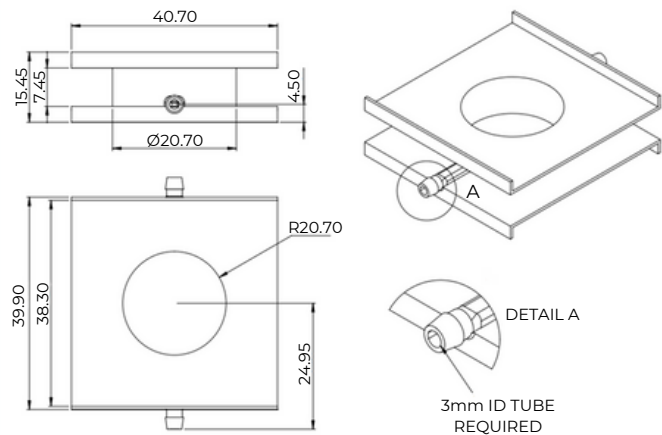

Tolerances: ISO 2768-1m unless otherwise specified

03 SPECIFICATIONS

HEAT DISSIPATION

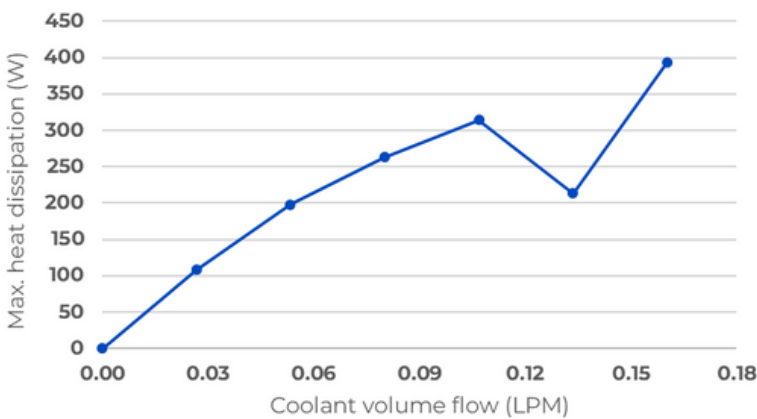

*Heat dissipation considering 100°C fixed coil-former temperature.

PRESSURE DROP

